

FEATURES

- Bridging-over contact configurations for heavy inductive load breaking
- 1 Form X and 2 Form X contact form
- Quick connect, PCB terminal, screw mounting for choice
- "Great Wall" mark approved
- Other approvals pending

TYPICAL APPLICATIONS

- Package air conditioners
- Heaters and refrigeration control
- UPS

CONTACT RATING

Form	1 Form X (1QH)	2 Form X (2QH)
Resistive	30A, 240VAC	2 x 25A, 240VAC

CONTACT DATA

Material	AgCdO	
Initial Contact Resistance	50 mΩ max. at 0.1A, 6VDC	
Service Life	Mechanical	5 x 10 ⁶ ops.
	Electrical	10 ⁵ ops.

UL/CSA RATING

Form	1 Form X (1QH)	2 Form X (2QH)
Resistive	30A, 277VAC	25A, 277VAC
TV	10A, 125VAC	10A, 125VAC
Motor	1.5HP, 125VAC	1HP, 125VAC
	3HP, 277VAC	2HP, 277VAC
	86LRA, 20FLA, 125VAC	69LRA, 16FLA, 125VAC
	60LRA, 14.1FLA, 277VAC	43LRA, 10FLA, 277VAC

COIL DATA

Type	Coil Voltage Code	Nominal Voltage (VDC/VAC)	Resistance (Ω) ±10%		Must Operate Voltage max. (VDC/VAC)	Must Release Voltage min. (VDC/VAC)
			Power Consumption			
DC	003	3	4.7	1.9W	2.25	0.3
	006	6	18.8		4.5	0.6
	012	12	75.0		9.0	1.2
	024	24	300.0		18.0	2.4
	048	48	1200.0		36.0	4.8
	100	100	5200.0		75.0	10.0
	110	110	6300.0		82.5	11.0
AC	220	220	21000.0	165.0	22.0	
	006	6	8.8	1.7 – 2.7VA	4.8	0.6
	012	12	35.0		9.6	1.2
	024	24	130.0		19.2	2.4
	048	48	480.0		38.4	4.8
	110	110	2150.0		88.0	11.0
	/120	/120			/96.0	/12.0
220	220	8880.0	176.0		22.0	
/240	/240		/192.0	/24.0		

CHARACTERISTICS

Operate Time	30 ms. max.
Release Time	30 ms. max.
Insulation Resistance	100 MΩ, at 500 VDC, 50%RH
Dielectric Strength	4000 Vrms, 1 min. between coil and contacts 2000 Vrms, 1 min. between open contacts 2000 Vrms, 1 min. between adjacent contacts
Shock Resistance	10 g, 11ms. functional; 100 g, destructive
Vibration Resistance	DA 1.5mm, 10 - 55 Hz
Ambient Temperature	-55°C to 70°C
Weight	90 g, approx.

ORDERING DESIGNATION

Example:		HG4505 /	220	A -	1QH	1	C	4	G
Model									
Coil Voltage Code									
DC/AC									
Nil: DC Coil; A: AC Coil									
Contact Form									
1QH: 1 Form X; 2QH: 2 Form X									
Version									
1: Sealed; 2: Dust Cover									
Contact Material									
C: AgCdO; S: AgSnInO									
Mounting Version									
Nil: Quick Connect; 4: PCB Terminal; 6: Screw Terminal									
Contact Gap									
Nil: Standard; G: Big Gap									

REFERENCE CURVES

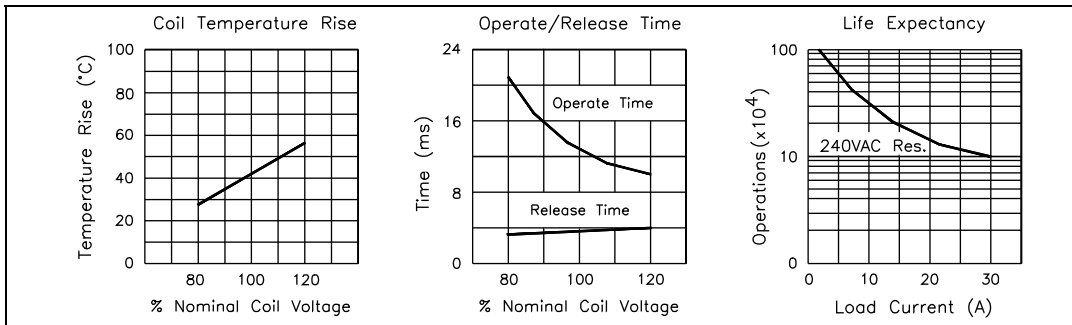

OVERALL DIMENSIONS, MOUNTING HOLES AND WIRING DIAGRAMS (mm)

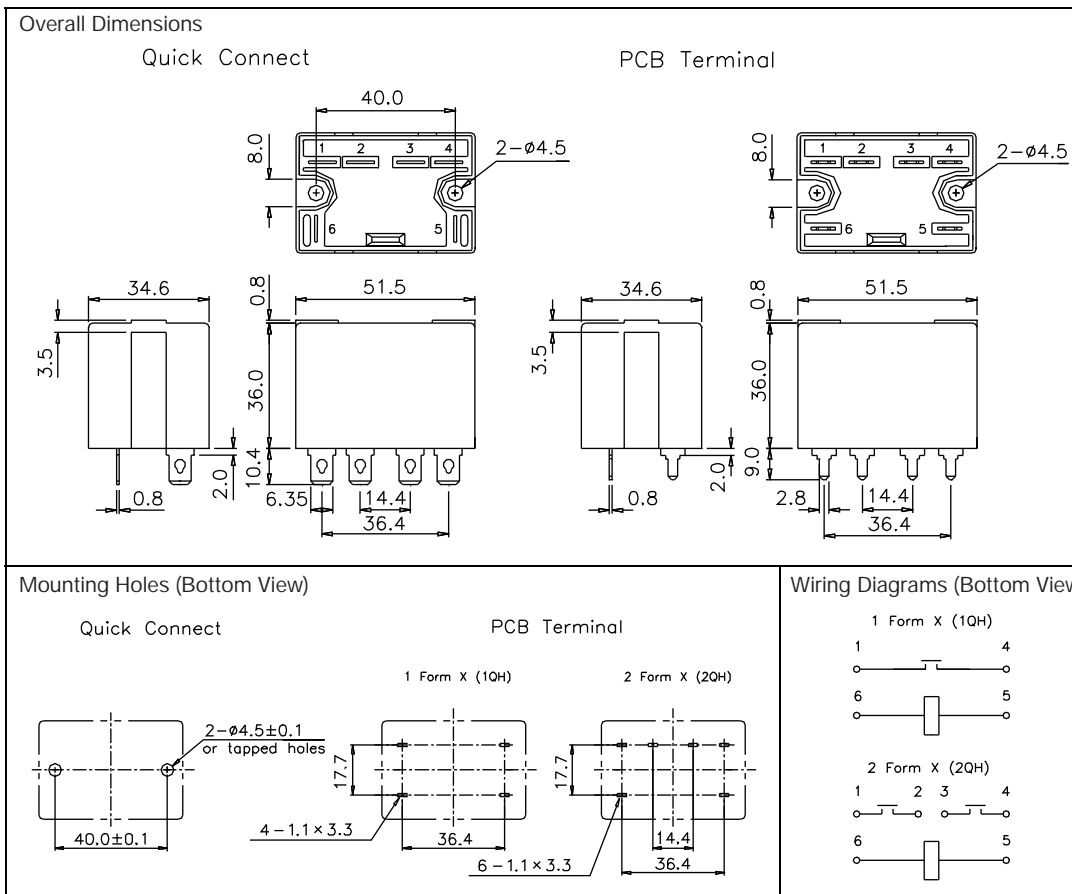

NOTES

- All parameters, unless otherwise specified, are measured at ambient temperature 23°C.
- Custom-made services available with operational quantity. Please let us know your special requirements.
- Specifications subject to change without prior notice.

T Y H Enterprise Limited
 Room 1620B, Nan Fung Centre
 264-298 Castle Peak Road
 Tsuen Wan, N.T.
 Hong Kong

Tel: 852-2416-0132
 Fax: 852-2413-6229
<http://www.tyhhk.com>
 email: info@tyhhk.com

Plant: Shanghai Hi-Gradex Relay Mfg. Co., Ltd
 918 Shixin Road
 Airport Town
 Pudong New Area
 Shanghai 201202
 China

Tel: 86-21-6299-5619 / -5877
 Fax: 86-21-6299-5619
 email: tyhesh@online.sh.cn