

FEATURES

- 30A switching capacity
- PCB + QC termination
- Meets UL508 and UL873 spacing requirements

TYPICAL APPLICATIONS

- Power supply device
- Industrial control
- Home appliances
- Heating, refrigeration, ventilation

CONTACT RATING

Form		1 Form A (1H)	1 Form B (1D)	1 Form C (1Z)	
				NO	NC
Rated Load	240VAC	30A	15A	20A	10A
	28VDC	30A	10A	20A	10A
Max. Switching Current		30A	15A	20A	10A
Max. Switching Voltage		277VAC/30VDC			
Max. Continuous Current		30A	15A	20A	10A
Max. Switching Power		8.31KVA 900W	4.155KVA 450W	5.54KVA 600W	2.77KVA 300W
Min. Load		1A, 5VDC/12VAC			

UL/CSA RATING

Load Type	Voltage	1 Form A (1H)	1 Form B (1D)	1 Form C (1Z)	
				NO	NC
General Purpose	240VAC	30A	15A	20A	10A
Resistive	240VAC	30A	15A	20A	10A
	28VDC	20A	10A	20A	10A
Motor	240VAC	2HP	0.5HP	2HP	0.5HP
	120VAC	1HP	0.25HP	1HP	0.25HP
LRA/FLA	240VAC	80A/30A	30A/10A	50A/20A	20A/7A
	120VAC	98A/22A			
Tungsten	120VAC	TV5	TV3	TV5	TV3
Ballast	277VAC	10A	3A	10A	3A

CONTACT DATA

Material		AgCdO, AgSnOInO
Initial Contact Resistance		50 mΩ, max. at 0.1A, 6VDC
Service Life	Mechanical	10 ⁷ ops.
	Electrical	10 ⁵ ops.

COIL DATA

Coil Voltage Code	Nominal Voltage (VDC)	Resistance (Ω)±10%	Power Consumption	Must Operate Voltage Max. (VDC)	Must Release Voltage Min. (VDC)
005	5	27	0.9W	3.75	0.5
006	6	40		4.50	0.6
009	9	97		6.75	0.9
012	12	155		9.00	1.2
024	24	660		18.00	2.4
048	48	2,560		36.00	4.8
110	110	10,330		82.50	11.0

CHARACTERISTICS

Operate Time	15 ms. typical
Release Time	10 ms. typical
Insulation Resistance	1000 MΩ, at 500VDC, 50%RH
Dielectric Strength	1500 Vrms, 1 min. between open contacts 2500 Vrms, 1 min. between coil and contacts
Shock Resistance	10 g, 11ms, functional; 100 g, destructive
Vibration Resistance	DA 1.5mm. 10 - 55 Hz
Power Consumption	0.9W, approx.
Ambient Temperature	-55 to 85°C operating, -40 to 130°C storage
Weight	30 g, approx.

ORDERING DESIGNATION

Example:	HG4138B /	012 -	1Z	0	1	F
Model						
Coil Voltage Code						
Contact Form	1H: 1 Form A; 1D: 1 Form B; 1Z: 1 Form C					
Mounting Version	0: PCB Mount					
Version	1: Sealed; 2: Dust Cover					
Thermal Class	Nil: UL Class B; F: UL Class F					

REFERENCE CURVES

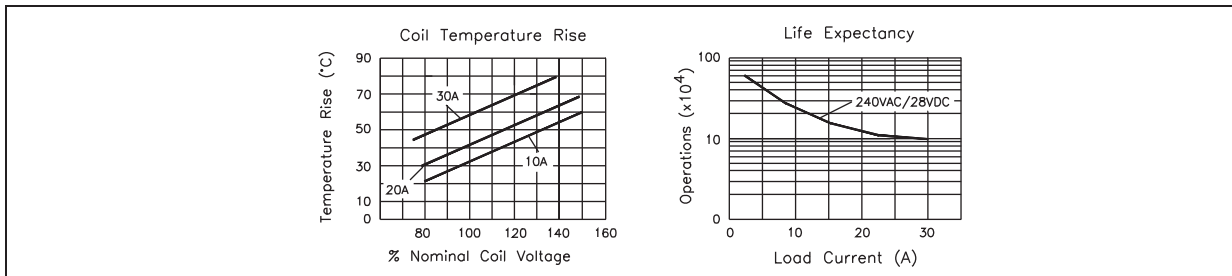

OVERALL DIMENSIONS, MOUNTING HOLES AND WIRING DIAGRAM (mm)

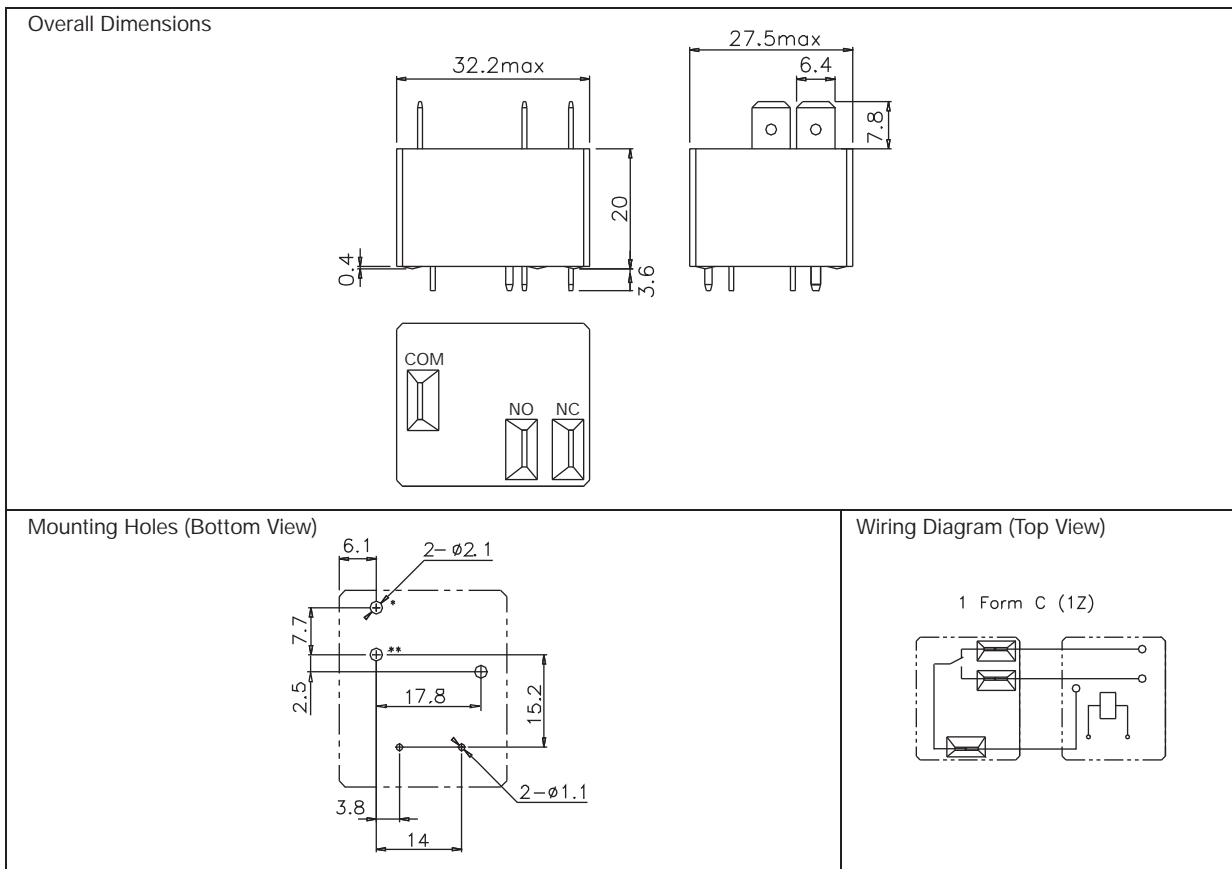

NOTES

1. All parameters, unless otherwise specified, are measured at ambient temperature 23°C.
2. In mounting holes drawing, the * holes is not needed for 1 Form A, the ** hole is not needed for 1 Form B.
3. To exert optimum electrical life, please remove the tape of sealed version after cleaning process.
4. Custom-made services available with operational quantity. Please let us know your special requirements.
5. Specifications subject to change without prior notice.

T Y H Enterprise Limited
 Room 1620B, Nan Fung Centre
 264-298 Castle Peak Road
 Tsuen Wan, N.T.
 Hong Kong

Tel: 852-2416-0132
 Fax: 852-2413-6229
<http://www.tyhk.com>
 email: info@tyhkh.com

Plant: Shanghai Hi-Gradex Relay Mfg. Co., Ltd
 918 Shixin Road
 Airport Town
 Pudong New Area
 Shanghai 201202
 China

Tel: 86-21-6299-5619 / -5877
 Fax: 86-21-6299-5619
 email: tyhesh@online.sh.cn