

FEATURES

- Miniature type, general purpose applications
- 2 to 4 poles contact form
- DC and AC coil available
- Various mounting options include socket, PCB and flange
- UL, CUR approved

TYPICAL APPLICATIONS

- Machine tools
- Medical equipment
- Industrial control
- Transportation

CONTACT RATING

| Form | 2 Form C (2Z), 3 Form C (3Z) | | 4 Form C (4Z) | |
|------------------------|------------------------------|------------------|------------------|------------------|
| | Standard | Heavy Duty | Standard | Heavy Duty |
| Rated Load | 5A, 220VAC/30VDC | 7A, 220VAC/30VDC | 3A, 220VAC/30VDC | 5A, 220VAC/30VDC |
| Max. Switching Current | 5A | 7A | 3A | 5A |
| Max. Switching Voltage | 250VAC/125VDC | | | |
| Max. Switching Power | 1100VA/150W | 1540VA/210W | 660VA/90W | 1100VA/150W |

UL/CUR RATING

| Form | 2 Form C (2Z) | 3 Form C (3Z) | 4 Form C (4Z) |
|-------------|------------------|------------------|------------------|
| General Use | 3A, 240VAC/30VDC | | |
| Resistive | 7A, 250VAC/30VDC | 5A, 250VAC/30VDC | 5A, 250VAC/30VDC |

CONTACT DATA

| | | |
|----------------------------|-------------------------|--|
| Material | AgCe | |
| Initial Contact Resistance | 50 mΩ max. at 1A, 30VDC | |
| Service Life | Mechanical | 2 x 10 ⁷ ops. |
| | Electrical | 2 x 10 ⁵ ops. for standard version 10 ⁵ ops. for heavy duty version |

COIL DATA

| Type | Coil Voltage Code | Nominal Voltage (VDC/VAC) | Resistance (Ω) ±10% | | Must Operate Voltage max. (VDC/VAC) | Must Release Voltage min. (VDC / VAC) |
|------|-------------------|---------------------------|---------------------|-------------------|-------------------------------------|---------------------------------------|
| | | | | Power Consumption | | |
| DC | 005 | 5 | 27.5 | 0.9W | 4.0 | 0.5 |
| | 006 | 6 | 40 | | 4.8 | 0.6 |
| | 012 | 12 | 160 | | 9.6 | 1.2 |
| | 024 | 24 | 650 | | 19.2 | 2.4 |
| | 048 | 48 | 2600* | | 38.4 | 4.8 |
| | 110 | 110 | 11000* | | 88.0 | 11.0 |
| AC | 006A | 6 | 11.5 | 1.2VA | 4.8 | 1.8 |
| | 012A | 12 | 46 | | 9.6 | 3.6 |
| | 024A | 24 | 184 | | 19.2 | 7.2 |
| | 048A | 48 | 735 | | 38.4 | 14.4 |
| | 120A | 120 | 4550* | | 96.0 | 36.0 |
| | 220A/240A | 220/240 | 14400* | | 176.0 | 66.0 |

CHARACTERISTICS

| | |
|-----------------------|--|
| Operate Time | 25 ms. |
| Release Time | 25 ms. |
| Insulation Resistance | 1000 MΩ, at 500 VDC, 50%RH |
| Dielectric Strength | 1500 Vrms, 1 min. between coil and contacts 1000 Vrms, 1 min. between open contacts |
| Shock Resistance | 10 g, 11ms. functional; 100 g, destructive |
| Vibration Resistance | DA 1.5 mm, 10 - 55 Hz |
| Ambient Temperature | -55°C to 70°C |
| Weight | 37 g, approx. |

ORDERING DESIGNATION

| | | | | | | | | |
|--|----------|-----|-----|----|---|---|---|---|
| Example: | HG4104 / | 012 | A - | 4Z | 4 | D | C | H |
| Model | | | | | | | | |
| Coil Voltage Code | | | | | | | | |
| DC/AC Nil: DC Coil; A: AC Coil | | | | | | | | |
| Contact Form 2Z: 2 Form C 3Z: 3 Form C 4Z: 4 Form C | | | | | | | | |
| Version Nil: Solder Lug 4: PCB 6: Top Flange 6A: Bottom Flange 6B: Lateral Flange | | | | | | | | |
| Indicator Nil: Without LED; D: With LED | | | | | | | | |
| Contact Material C: AgCe | | | | | | | | |
| Duty Version Nil: Standard; H: Heavy Duty | | | | | | | | |

REFERENCE CURVES

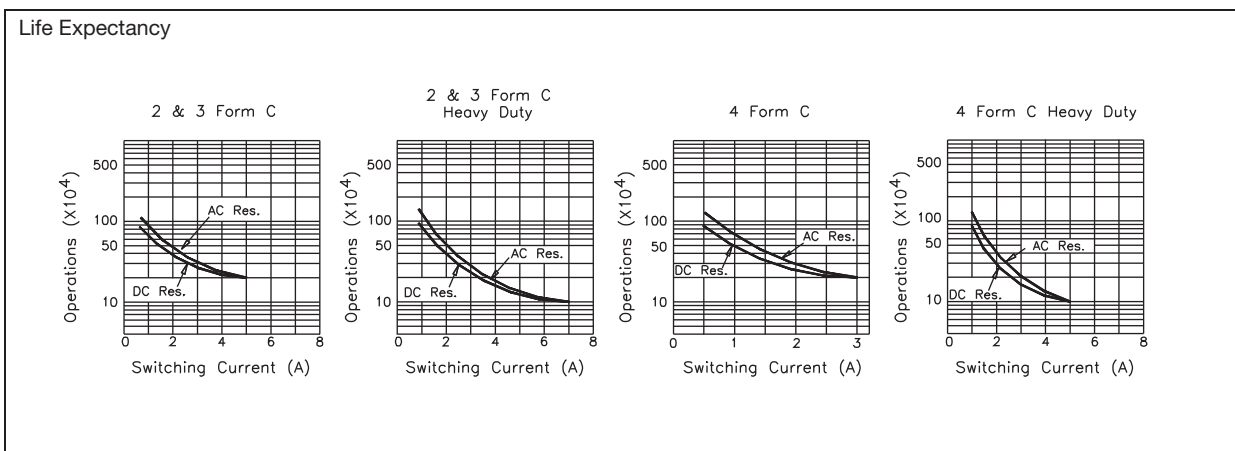

OVERALL DIMENSIONS, MOUNTING HOLES AND WIRING DIAGRAMS (mm)

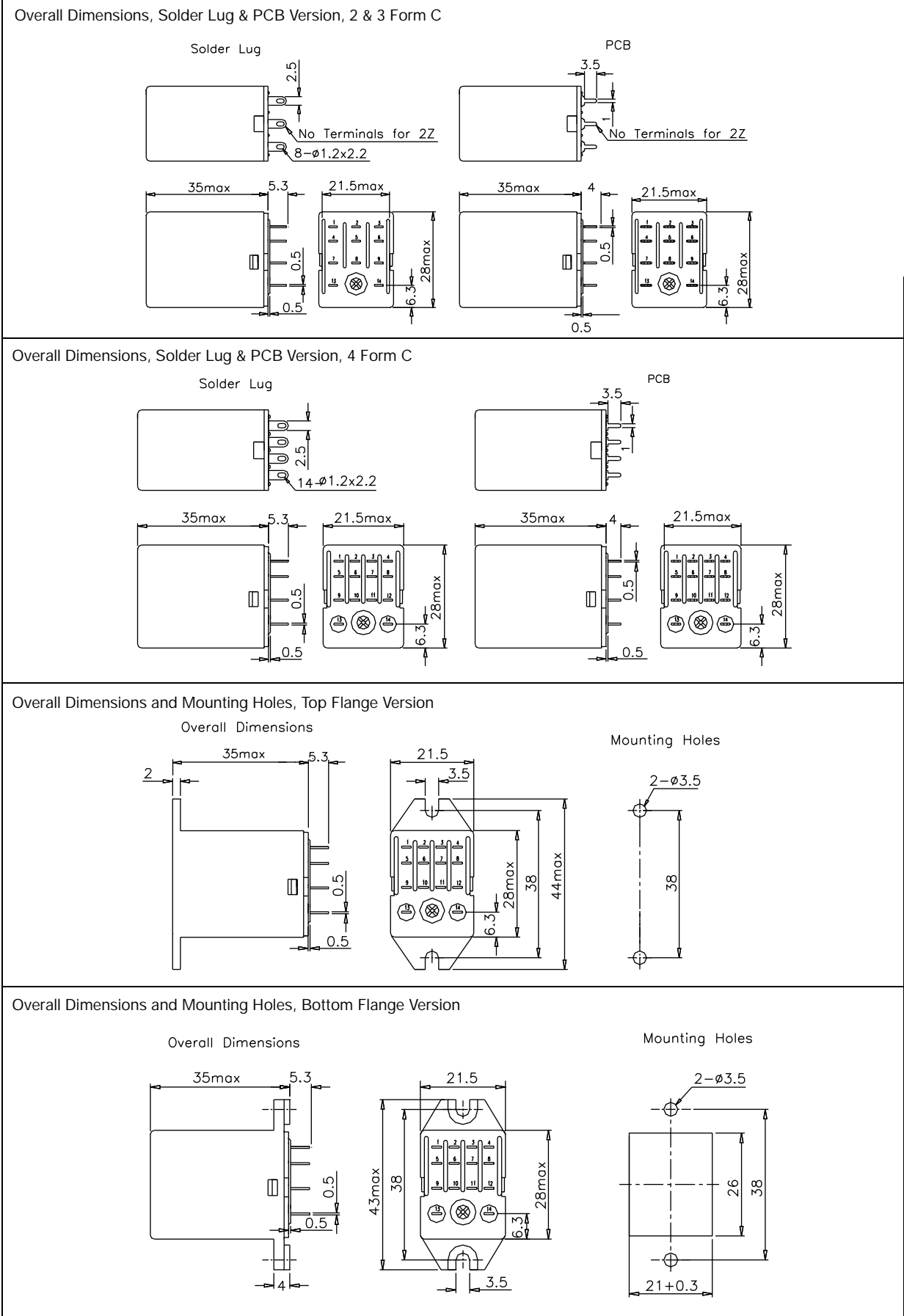

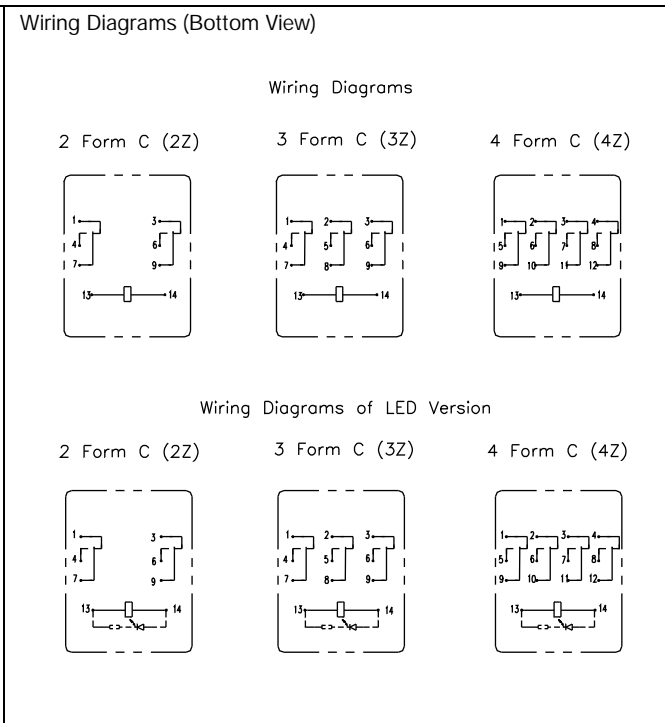
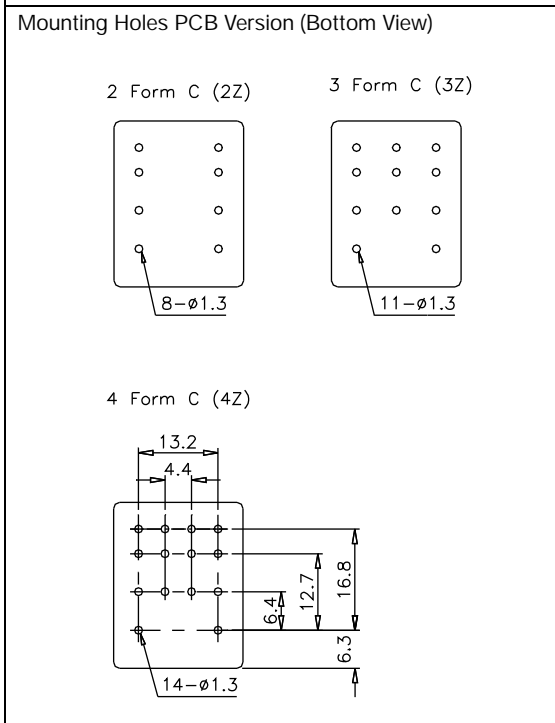
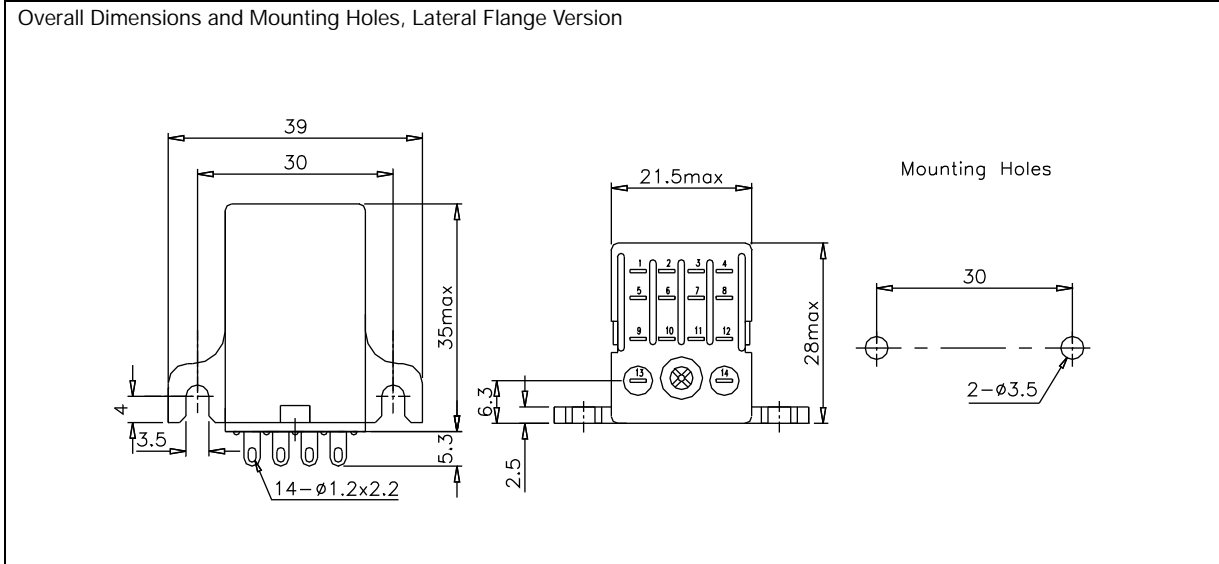

NOTES

1. All parameters, unless otherwise specified, are measured at ambient temperature 23°C.
2. Coil resistance with * mark is ±15%.
3. Custom-made services available with operational quantity. Please let us know your special requirements.
4. Specifications subject to change without prior notice.

T Y H Enterprise Limited
 Room 1620B, Nan Fung Centre
 264-298 Castle Peak Road
 Tsuen Wan, N.T.
 Hong Kong
 Tel: 852-2416-0132
 Fax: 852-2413-6229
<http://www.tyhhk.com>
 email: info@tyhhk.com

Plant: Shanghai Hi-Gradex Relay Mfg. Co., Ltd
 918 Shixin Road
 Airport Town
 Pudong New Area
 Shanghai 201202
 China
 Tel: 86-21-6299-5619 / -5877
 Fax: 86-21-6299-5619
 email: tyhesh@online.sh.cn